



# **PROCEDURES FOR LOADING AND OFF-LOADING LIQUID CHLORINE CONTAINERS**

**August 2009**

**Edition 1**

Although chlorine is a hazardous material in terms of reactivity and toxicity it can be handled safely provided that appropriate precautions are observed. For many years, International Associations such as the Chlorine Institute, the Japan Soda Industry Association and Euro Chlor have developed guidelines to assist their members with the safe handling of chlorine.

The World Chlorine Council® provides this document to describe common worldwide practices for loading and off-loading chlorine and is intended to help facilities located in regions where no technical publications have been issued by a regional trade association. Where such guidance exists, that guidance should be used instead of these generic global recommendations. Along with this document, the WCC has posted the publications from regional WCC members applicable to their specific various regions around the world. See Section 7 of this document for more information.

For cultural, legal and historical reasons it is not possible to have a common detailed document applicable throughout the world. This document focuses on the most important items necessary to safely handle chlorine during loading and off-loading operations.

It is highly recommended that all national and local legislation concerning chlorine transportation and safety are carefully checked for compliance.

## TABLE OF CONTENTS

1	GENERAL INFORMATION	6
1.1	Location	6
	1.1.1 Location of the Loading /Off-loading Operation Point	6
1.2	Access Platform	7
	1.2.1 Pipework, Valves, Accessories	7
	1.2.2 Movement of the Shipping Container	7
	1.2.3 Movement of Small Containers	8
1.3	General Protection	8
1.4	Personnel in Charge of Loading and Off-loading Operation	9
1.5	Personal Protective Equipment	9
1.6	Nitrogen Trichloride Risk	9
1.7	Choice of Connections	9
	1.7.1 Articulated Arms	10
	1.7.2 Flexible Hoses	10
	1.7.3 Flexible Steel Pipes	10
	1.7.4 Hoses for Instrument Air	10
1.8	Relief Valves	10
1.9	Absorption System	11
1.10	Protection against Liquid Expansion	11
1.11	Protection and Alarms	11
1.12	Accident Reporting	12
2	LOADING	12
2.1.	Chlorine Transfer Methods	12
	2.1.1 Pump transfer	12
	2.1.2 Inert Gas or Air Padding	12
	2.1.3 Chlorine Padding	13
2.2	Loading Operations	13
	2.2.1 Before Loading	13
	2.2.1.1 The Container Itself	13
	2.2.1.2 The Container Contents	14
	2.2.1.3 The State of the Accessories	14
	2.2.1.4 Specific Precautions	15
	2.2.2 During Loading	15
	2.2.2.1 Accessories	15
	2.2.2.2 Control of the Total Load	15
	2.2.2.3 Continual Supervision	16
	2.2.3 After Loading	16
	2.2.4 Inspection before Dispatch	16

3	OFF-LOADING	17
3.1	General Statements	17
3.2	Choice of Off-Loading Method	17
3.2.1	Off-Loading in the Gaseous Phase	18
3.2.2	Off-loading in the Liquid Phase	18
3.2.2.1	Displacement by Inert Gas (Dry Air or Nitrogen)	18
3.2.2.2	Displacement by Compressor	18
3.2.2.3	Displacement by a Heating System	19
3.3	Off-loading Operations	19
3.3.1	Before Off-loading	19
3.3.1.1	The Container Itself	19
3.3.1.2	Connections	20
3.3.2	Off-loading	20
3.3.3	Empty Container	20
3.3.4	Purging of Connections	21
3.3.5	Disconnection	21
4	Drums and Cylinders	21
4.1	Preliminary Checks	21
4.2	Connection of the Container to the Loading Station	22
4.3	Degassing and Purging the Container	22
4.4	Gland Nuts and Spindle	22
4.5	Cleaning Valve, Gland Nut and Fitting	22
4.6	Keeping Records of Maintenance Operations	22
4.7	Leak Testing	23
4.8	Precaution against Overfilling Risk	23
4.9	Disconnecting Process	23
4.10	Recording the Appropriate Items:	23
4.11	Confirmation of Quantity Loaded	23
4.12	Place the Container in the Storage Area	24
4.13	Loading of the Container on to the Transport Equipment	24
5	APPENDICES	24
6	CHECKLISTS	32
7	REFERENCE DOCUMENTS	39
7.1	Euro Chlor	39
7.2	Japanese Soda Industry Association	39
7.3	Chlorine Institute	39
7.4	Alkali Manufacturers' Association of India	39
7.5	RusChlor	39

**TABLE OF FIGURES**

APPENDIX 1: FLOW FOR FILLING A CONTAINER WITH CHLORINE PUMP	25
APPENDIX 2: FLOW FOR FILLING A CONTAINER BY CHLORINE GAS PRESSURE	26
APPENDIX 3: OFF-LOADING TO USER IN THE GASEOUS PHASE	27
APPENDIX 4: OFF-LOADING TO USER IN THE LIQUID PHASE WITH DRY GAS PRESSURE	28
APPENDIX 5: OFF-LOADING TO STOCK TANK IN THE LIQUID PHASE WITH DRY GAS PRESSURE	29
APPENDIX 6: OFF-LOADING TO STOCK TANK IN THE LIQUID PHASE WITH COMPRESSOR	30
APPENDIX 7: FLOW FOR FILLING A LIQUID CHLORINE TON CYLINDER	31

# 1 GENERAL INFORMATION

This information is provided to assist companies involved with the loading and off-loading of chlorine. It is not intended as a substitute for the relevant national or international regulations. The user should review the National and Local regulations as these can be very different depending on the country. Following are some examples of different requirements:

- In North America and Russia, railcars must have relief devices whereas these are not used in Europe.
- Russian legislation bans off-loading of chlorine in the gas phase for containers over 1 cubic meter. It is allowed with constraints on smaller cylinders. In other countries off-loading by vapour is common practice for chlorine cylinders
- Plastic hoses with reinforced metal covering are typically used in North America but are not recommended in Europe

This document does not include:

- Detailed information on the construction of the containers (ton cylinders, road tank, rail tank and ISO-containers)
- Procedures for the initial commissioning of the installation
- Detailed requirements for accessories such as pipework, flanges, joints, nuts, and bolts
- The certification process for the equipment.
- Procedures for periodic inspection and hydraulic test of the containers

## 1.1 Location

### 1.1.1 Location of the Loading /Off-loading Operation Point

The Loading / Off-loading location should be:

- Above ground level
- On a level area to minimize the chance of accidental car movement
- with sufficient clearance from other equipment
- Adequately separated from traffic
- As close as possible to the chlorine user or storage (minimizes length of pipelines)
- Accessible from at least two directions
- Separated from other facilities and especially from potential sources of heat
- Preferably covered by a roof to protect the workers and the equipment from snow, rain and sun
- Complete with concrete flooring
- Equipped with leveled rails to allow for the slow rolling of chlorine tonner cylinders

## 1.2 Access Platform

The access platform to the tanker should:

- Be of sufficient size to allow for adequate working space
- Provide easy access (stairway)
- Incorporate protection against falling from truck or railcar
- Have an independently supported mobile platform (should not rest on the container except for a specific provision where the container is locked into position according to the location of the access platform).

### 1.2.1 Pipework, Valves, Accessories

The piping, valves, accessories and equipment should be located where it cannot be subjected to a fire. The system should be protected from mechanical damage resulting from the impact of vehicles, falling objects, etc.

The piping systems (liquid chlorine, gaseous chlorine, vent system, dry inert gas), should be clearly marked (for example, by the use of a color code) in order to provide for immediate identification by the operating personnel.

The “open-close” position of the major valves should also be identified. This feature is particularly important for pneumatic valves where the valve position may not be easy to recognize.

### 1.2.2 Movement of the Shipping Container

All precautions should be taken to avoid the movement of the container during the loading or off-loading operation.

Movement of the vehicle by gravity can be avoided if the location has no slope and the rails are level. Unauthorized movement of the vehicle and the container can be prevented by the use of wheel chocks. Access by other vehicles to the loading/off-loading facility must be prevented. This can be accomplished by the use of rigid barriers which are preferably locked into position. In the case of a rail loading/off-loading installation movable buffers, or locked-off rail points can be used. Similar measures should be taken for road vehicles.

If the container is fitted with automated pneumatic valves the opening of these should be interlocked with the protective systems that prevent movement of the container or access to the station by other vehicles.

For loading/off-loading of road tankers, it is preferred that the truck only moves in the forward direction. This eliminates the additional risk associated with the vehicle backing into or out of the location. Before the transport vehicle is disconnected from the container it must be verified that the drop legs are strong enough, that they have been locked into position and that the ground is solid enough to prevent roll over.

The loading/ off-loading point should have adequate lighting. There must be a visual indication that the container is in the loading/off-loading step. This includes anytime it is not safe to move the container.

Sufficient clearance must be provided between the container and the loading/off-loading facility. If the container is moved with the dome open it can not come into contact with any part of the facility. The valve access platform will be designed to allow safe and easy access and there will be no possibility of the access platform striking the container. If the access platform has adjustable elevations then the stairway must accommodate all positions to allow safe access.

### 1.2.3 Movement of Small Containers

Countries have different requirements for the movement and storage of small chlorine cylinders.

Russian legislation requires that ton containers be transported only in an upright position. However, these containers may be stored, loaded, or off-loaded in the horizontal or vertical or position. A special grappling accessory called the “container tilter” can be used to change the orientation of the ton container. In the United States and Europe one ton containers must be stored horizontally.

Some countries limit the number of containers allowed on a truck. Some countries require two trained drivers with every truck shipment.

## 1.3 General Protection

- The operating manual should contain line diagrams of the piping and equipment, detailed descriptions of the equipment as well as procedures for safe operation. This manual should be available to the operating personnel at all times.
- A plant log of the operations (loading/off-loading) should be maintained by the operating personnel.
- Up-to-date records should be maintained on the transport containers. The records should include the identification of the transport containers, their tare weight, their laden weight, their pressure, and their general physical state, as well as any major items of maintenance.
- A visual and audible alarm should be installed in and around the location to alert workers in case of chlorine leak.
- An emergency plan with detailed instructions for responding to an emergency should be readily available. The operators and the emergency response team must be trained on these procedures annually.
- Wind direction devices should be installed. This allows the operators to predict the path of a chlorine release and to warn the potentially affected areas.
- All personnel should be specifically instructed in the means for dealing with chlorine releases. Periodic training exercises should be conducted.

To facilitate the local intervention, the installation of fixed water curtains or mobile water sprays should be considered. Provisions should then be taken to avoid possible discharge of water onto the liquid chlorine or onto the area of leakage.

#### **1.4 Personnel in Charge of Loading and Off-loading Operation**

All operations should be carried out by personnel (including drivers) who have been specifically trained for this work. This includes practicing emergency drills. Checklists starting from the arrival of the container to its departure are very useful tools for workers in charge of loading and off-loading operations. Since each country has different legal requirements and the equipment is designed to suit those requirements, a common checklist is not achievable.

#### **1.5 Personal Protective Equipment**

Every worker must wear the appropriate Personal Protective Equipment as designated by the facility. Some of this is needed to prevent chlorine burns from liquid exposure. Self-contained breathing apparatus and protective clothing suitable for dealing with a chlorine leak should be available in storage cabinets located near to the loading/off-loading point and be accessible at all times in case of emergency.

Driver shall have all the necessary items of protective clothing and safety equipment.

To carry out the connections between the container and the loading/off-loading point the operating personnel should wear protective breathing air equipment.

#### **1.6 Nitrogen Trichloride Risk**

The system design should prevent the accumulation or concentration of nitrogen trichloride.

Off-loading of bulk containers in the gas phase is not recommended as it concentrates the nitrogen trichloride in the remaining liquid, leading to potentially dangerous high concentration. At least one association's recommendations allow for the vapor unloading of chlorine from ton containers and smaller sizes provided the nitrogen trichloride concentration in the filled container does not exceed 20 ppm.

#### **1.7 Choice of Connections**

The connection between the storage installation and the container is the weakest point of the system and should be designed and installed according to a detailed specification. A visual examination of the flexible connections and pressure test of the system should be conducted prior to each introduction of chlorine. Maintenance and routine preventive replacement of the components is required to maintain the mechanical integrity.

Breakaway coupling devices are used at some facilities to prevent releases if the container is inadvertently moved during loading/off-loading operations; alternative technical measures can also be taken to avoid any possible movement of the container.

### 1.7.1 Articulated Arms

Articulated or flexible joint arms of 25-50 mm diameter are available for use with liquid chlorine.

This equipment is recommended only for installations requiring a high flow rate, i.e. operations transferring directly into fixed storage. These devices are not recommended for off-loading at low rates on a continuous basis directly to the point of use

### 1.7.2 Flexible Hoses

Flexible hose connections with a diameter up to 50 mm are available for chlorine use. These flexible connections are constructed in a material suitable for the application with a pressure-containing metal covering or of solid high-nickel alloys.

### 1.7.3 Flexible Steel Pipes

Flexible steel pipes can be made in mild steel up to a maximum of 50 mm diameter.

This form of connection can be used either for off-loading to storage or for direct connection to the point of use.

It must be noted that the use of flexible steel pipes on liquid chlorine is forbidden in some countries.

Copper can be used in this duty with smaller diameter piping (<25 mm). It should also be stress-relieved on a regular basis to maintain the flexibility of the metal and to avoid cracks.

### 1.7.4 Hoses for Instrument Air

Instrument air hoses supply the motive force to operate the container loading/off-loading valves.

In North America, the motive force may be required to both open and close the valves. In this case a hose reel is provided such that if the railcar is moved the hoses will stay connected long enough for the valves to be fully closed. Motion detectors at the railcar detect movement and automatically close the valves.

In Europe and some other areas, these valves require that air be applied to open them. Upon loss of air, the valves will automatically close. In this case the length of air hoses should be shorter than the chlorine hose. If the railcar is moved the shorter air hose will fail first resulting in the fail safe closing of the chlorine valves.

## 1.8 Relief Valves

In some regions, relief valves are not installed on rail and road chlorine tanks except for sea transportation as the potential for accidental release from the relief valves is believed to pose a greater risk than the over pressure scenarios resulting from over filling the container. In other regions, like North America and Russia, tanks are required to be fitted with relief valves.

Fixed site chlorine storage tanks typically are required to have relief valves. In many cases, a rupture disc is installed upstream of the relief valve. In such cases the space between the rupture disc and the relief valve must be monitored to insure that no leakage has occurred and the disc will function as intended (i.e., rupture in the event of over-pressure).

## 1.9 Absorption System

All installations that handle liquid chlorine must have a means of removing the remaining gaseous chlorine from the transfer system. This can be an absorption or neutralization system or by consumption of the chlorine within the factory. These systems should have the following features.

- The venting down of fixed or transport containers leads to the possibility of chlorine liquid being transferred with the purge gas, either during the venting down of the liquid chlorine piping, or following a mal-operation. A liquid trap should be installed in the purge gas line, which should contain a temperature or level alarm to indicate to the operating personnel the presence of chlorine liquid.
- It should also be possible, in the event of an incident involving the container, to reduce the pressure in the container by means of the chlorine purging system.

The absorption/neutralization installation must have a capacity designed to cope with the maximum reasonable chlorine quantity that could escape, and preferably be equipped with an emergency power supply. It is beyond the scope of this document to provide guidance on the design criteria for such an absorption/neutralization system.

## 1.10 Protection against Liquid Expansion

All sections of piping between two closed valves should be emptied following the operation of the two valves, unless provision has been made for the thermal expansion of the liquid. Such provision can be made by:

- Expansion vessels containing a permanent gaseous phase
- Bursting discs, with or without relief valve, leading to a closed vessel or to an absorption system; it may be directed to a collector drum connected to a chlorine absorption and neutralization installation. The bursting disc can be in PTFE protected graphite, high nickel alloy, stainless steel, nickel, or other appropriate material.

## 1.11 Protection and Alarms

The following equipment should be provided:

- Indication of the pressure in the transport container with a high pressure alarm
- Indication of the weight of the container with a high level alarm

- Indication of inert gas pressure
- Devices for the rapid isolation of the connection between the transport container and the loading/off-loading installation. This includes remotely operated valves on either end of the connection. These valves should close on failure of pressure in the motive fluid.
- A method of operation of the isolation valves should be provided at two locations with easy access and adequately removed from the loading/off-loading point such that in the event of accidental leakage they will always remain accessible.
- Automatic safety device to relieve over-pressure in the stock tank

It is preferable that these valves are grouped together in the same location. In so far as protection against expansion of liquid chlorine trapped between two valves is involved, see Section 1.9.

## 1.12 Accident Reporting

We must learn from each other. Any accident or other near-miss incident involving liquid chlorine should be investigated, the root cause should be determined and corrective actions should be taken. The learning from the incident should be reported on the standard form provided by WCC.

# 2 LOADING

A written checklist should be used during all operations, including, as appropriate, the approval of a supervisor before starting loading the equipment.

## 2.1. Chlorine Transfer Methods

Three methods are generally used:

### 2.1.1 Pump transfer

This method is generally used in large producing operations that have a low pressure storage system. See Appendix 1.

### 2.1.2 Inert Gas or Air Padding

The transfer gas such as dry air or nitrogen should have a dew point less than minus 40 degrees at atmospheric pressure, preferably monitored by an on-line analyzer; it should be clean and all impurities such as oil, dust, etc. removed. The use of inert gas from a combustion unit is not recommended, because of the risk of incomplete combustion which can lead to the introduction into the chlorine gas of a reactive material (hydrogen or methane, etc.) or the risk of combustion with shortage of oxygen leading to the presence of carbon monoxide and the eventual reaction to produce phosgene.

The compressed gas source being used on the storage tank should not be connected to any other installation unless a detailed review has been conducted.

Protection must be installed to prevent chlorine from back flowing into the air system. Even where not required by the regulatory authorities, many facilities have found it beneficial to separate the chlorine pad air system from other systems to avoid their contamination.

Instrument air should not be used for pressurizing the storage tank. This eliminates the risk of chlorine being backed into the control and safety systems.

Care must be taken to ensure excess inert gas does not result in an over-pressure situation.

In addition to on-line moisture monitoring described earlier in this section, it is recommended to have an on-line pressure monitoring system with appropriate controls to insure that the pad air system is maintained at a pressure sufficiently high to prevent chlorine from backing up into the air header and that the air header can not over-pressure any chlorine containing equipment to which it is connected.

### 2.1.3 Chlorine Padding

Chlorine compressors can be used to create a differential pressure between the fixed container and the transport tank. The compressed vapor is used as a pad gas to move liquid to the transport tank. The process must be designed to exclude moisture entry from ambient air leakage into the system. Adequate pad gas must always be available to maintain a positive pressure in the system. See Section 3.2.2.2 and Appendix 2.

## 2.2 Loading Operations

### 2.2.1 Before Loading

- Ensure the adequate state of the overall installation.
- Select the storage tanks to be used and ensure that there is an adequate amount of chlorine available to fill the container in a single operation.
- Ensure the adequate functioning of the gas absorption system.
- Confirm the suitability of the transport container for the transportation requirements prior to the connection of the container at the loading facility.

#### 2.2.1.1 *The Container Itself*

Before loading all containers should then be inspected to ensure that they are in a proper state to receive chlorine. These checks in particular include the following:

- The container is a suitable transport vehicle for liquid chlorine (labeling).
- The date when it was last inspected and the date of the next inspection.
- The maximum pressure and the minimum temperature for which the container and accessories have been constructed.

- Wheel chocks and other protective devices to ensure that the container cannot be moved during its loading operation are in place, as indicated in Section 1.1.

### 2.2.1.2 *The Container Contents*

The weight of the container should be compared with its tare weight. The gas tightness of the valves should be checked after removal of the blank flanges (to be confirmed by ammonia water). For this operation the operator should be wearing respiratory protection.

Important: when areas are searched for possible chlorine leaks using an ammonia solution, only the gas from the bottle should be directed to the equipment. Never squirt liquid ammonia solution on the potential leak source! The reaction between liquid ammonia and chlorine is quite violent and must be avoided.

After attaching the gaseous phase connection and its motive fluid, one should open the various valves which will give a reliable indication of the existing pressure within the container.

In the event of:

- Doubtful origin
- Significant variation from the tare weight
- Excessive or negative pressure
- Containers which have been used for gaseous phase off-loading by the customer

The container may require additional checks as indicated in Section 2.2.1.4.

Note: All joint rings or gaskets on the flexible connections should be replaced with each connection and the flange faces should be cleaned. The connections must be made correctly in accordance with the manufacturer's recommendations. This is to avoid any failures in this area. The operator *should attach particular importance to this operation.*

### 2.2.1.3 *The State of the Accessories*

A pressure check should be completed of the connections prior to introducing liquid chlorine. This should be done with the pad gas. It can also be done by opening the liquid valve on the mobile container in order to confirm the gas tightness of the various connections. At this stage the fixed installation liquid valve should remain closed.

Confirm that all the valves on the installation are in the right position and that in particular the connection between the liquid or gaseous chlorine systems and the vent gas absorption system has been closed.

#### 2.2.1.4 *Specific Precautions*

In the specific circumstances described above in Section 2.2.1.2, the following precautions should be taken:

- Venting

Where the contents of the container are in doubt they should always be vented to the absorption system.

- Overweight Containers

In circumstances where the origin of the container is known, and after confirming the chlorine content in the gaseous phase, the container should be vented down towards the chlorine handling system.

- Excessive Pressure

The container should be vented towards the absorption installation taking care to avoid any excess pressure developing in the vent headers.

- Negative Pressure

The container should be purged with dry air and the purge gas should be checked to confirm the absence of water. If there are still doubts about the presence of foreign materials (e.g. sulphuric acid, organic compounds ...) or the presence of water, the container should be inspected internally to confirm that there is no corrosion.

- Containers which have been off-loaded in the gaseous phase at the customers premises

This method of off-loaded can lead to an increased concentration of nitrogen trichloride and other non volatile materials in the liquid chlorine remaining in the container. This chlorine should be diluted with a fresh supply of liquid chlorine and afterwards purged in the liquid phase and treated in an appropriate manner.

### 2.2.2 During Loading

#### 2.2.2.1 *Accessories*

The valves on the fixed installation should be opened slowly in order to confirm that there are no leaks on any of the connections. During the loading operation the gas valve of the container can remain open in order to avoid an excessive increase in pressure. The vent gas should then be directed towards:

- Either the absorption system initially where there is an excessive quantity of inert gas present, and then towards the chlorine production system
- Or directly to the chlorine producing unit

#### 2.2.2.2 *Control of the Total Load*

It is essential that the total load is effectively checked before any transport vehicle leaves the loading installation. Overfilling a container can result in over-pressuring it due to thermal expansion of the chlorine. Each country may have different requirements on the maximum amount of chlorine allowed in each container. Compliance with the local laws is required. The maximum filling ratio must not be exceeded (1.25 tonnes per m<sup>3</sup> of water capacity, and in every instance a minimum of 5% free board at the maximum operating temperature). The methods

for controlling the total load are limited to the following in order of preference (preferably by continuous measurement).

- Measurement of the total weight of the filled container

The maximum gross weight must be carefully checked. In order to calculate the net weight, it is essential that the possible presence of residual chlorine in the container before loading has been adequately taken into account, Cross check the tare weight with the original tare weight for the vehicle being filled.

- Filling from a weighed stock tank
- Volumetric filling (difference in level, etc.)

In the two latter cases strict control must be maintained over the initial and final gross weight. It is also necessary to ensure that the vehicle was empty before commencing filling, e.g. by venting down. As soon as possible after loading, the total weight must be checked on a weigh scale. This must be done prior to allowing the vehicle to leave the facility.

#### 2.2.2.3 *Continual Supervision*

During the complete loading operation the loading point should be under continual supervision, either in person or by the use of cameras and detectors.

#### 2.2.3 After Loading

The following procedures should then be carried out:

- Close the valves on liquid chlorine.
- Vent the liquid connections to the facility handling system.
- Close the vent system valves at the fixed installation.
- Check the pressure within the container. One must take care to ensure that if there remains a separate pad gas in the container, the maximum pressure which may be reached during transport cannot exceed the maximum operating pressure of the container. Where pad gases are introduced into the container at the end of the loading sequence, a final venting down should be applied such that the pressure of the container is reduced to less than two bars above the equilibrium pressure for the given chlorine temperature.
- Close of the container gas valve.
- Vent down of all the connections.
- In order to disconnect the connections the operator should be wearing breathing protection equipment.
- Check the gas tightness of all the valves.
- Reinstall the blind flanges, with new joint rings or gaskets, on the valves of the container, which can then be locked closed for transportation.
- Care must be taken to avoid the entry of moisture into the flexible connections.

#### 2.2.4 Inspection before Dispatch

One should check in particular the following:

- Leak-tightness of joints and valves using ammonia vapor.
- The labeling of the vehicle as required by national regulations for transport containers.

Some facilities quarantine the filled containers for 24 hrs to allow the loaded material to achieve room temperature and higher container pressure. They then recheck for leaks, container test dates and correct quantities (weights)

### 3 OFF-LOADING

A written checklist should be used during all operations, including, if appropriate the approval of a supervisor before starting off-loading the equipment.

#### 3.1 General Statements

Chlorine can be off-loaded from the container

- To a fixed storage installation or
- For direct use in a chlorine consuming installation.

If the chlorine is off-loaded directly to the consuming installation, then the following issues must be addressed:

- The connection between the container and the fixed installation should be as described in Section 1.6.
- The design must prevent any return of reactive material into the transport container.

By this means an intermediate storage system for liquid chlorine, with all the implications for inspection and maintenance, can be avoided.

#### 3.2 Choice of Off-Loading Method

The following table indicates the recommended method of off-loading and the choice of phase for different conditions.

Usage rate C in kg/hr	Type of container	Liquid phase to fixed storage	Direct off-Loading into the process / vaporizer	
			Liquid phase	Gaseous phase
C < 100-150	Drums or cylinders	*Not necessary	by choice as a function of the extraction rate	
C > 150	Rail tankers Road tankers ISO- containers	*Recommended	See section 3.2.2	Not recommende d, see section 3.2.1
* Russian legislation bans offloading in the gas phase for containers over one cubic meter and restricts off loading in the gas phase for smaller containers.				

### 3.2.1 Off-Loading in the Gaseous Phase

This method of Off-Loading is basically not recommended for bulk chlorine due to the increase of nitrogen trichloride concentration in the remaining liquid phase, leading to potentially dangerous high concentration. See Section 1.5.

It can only be used for small containers and for an installation using chlorine gas at low pressure (the order of 2 bars absolute). A careful study is needed because the pressure in the container resulting from the thermal equilibrium with ambient conditions is limited to a fairly small value. This can lead to the backflow of moisture or reactive materials into the container. It is also more difficult to control the off-loading rate. See Appendix 3.

The extraction rate depends upon the conditions of thermal equilibrium with the outside temperature and is usually limited to an off-loading rate of 150 kg/hour.

In any case, the supplier of the liquid chlorine needs to inform the chlorine user of the risk of nitrogen trichloride concentration. If this method of off-loading in the gaseous phase is employed the supplier must take appropriate measures to avoid  $\text{NCl}_3$  accumulation in the tank.

### 3.2.2 Off-loading in the Liquid Phase

Depending on the off-loading rate required one may use:

- Pressure within the container resulting from thermal equilibrium with ambient conditions outside.
- Putting of the container under pressure.

Off-loading can be accomplished by a variety of methods including pad gas (dry air or nitrogen are common), a transfer compressor; a chlorine vaporizer or other heating system. Because of the complexities of such systems chlorine vaporizers are not recommended for small users.

#### 3.2.2.1 *Displacement by Inert Gas (Dry Air or Nitrogen)*

The pressurization gas must be dry and have back flow prevention installed.

See Section 2.2.2 and Appendixes 4 & 5.

#### 3.2.2.2 *Displacement by Compressor*

Chlorine compressors may also be used to compress vapour from the fixed storage for use as pad gases to remove liquid from the transport tank. Temperature in the transport tank should be maintained at a level such that the chlorine gas from the compressor will not liquefy and possibly overfilling the transport tank rather than increasing the pressure to pad the liquid out.

This system can only be used where the container is off-loaded towards a fixed storage installation. See Appendix 6.

The following issues should be addressed:

- The risk of contact between chlorine and the lubrication oil of the machine must be eliminated, unless special greases are used which are non-reactive to chlorine e.g. chloro-fluorinated grease.
- The risk of recycling chlorine liquid into the compressor inlet must be eliminated. Liquid entrainment in the chlorine gas to the compressor inlet must also be prevented.
- The temperature of chlorine in the compressor should be limited to 120°C by various safety measures which provide for shut-down of the compressor if this limit is exceeded. This is to prevent a chlorine-iron fire.
- If the compressor is cooled, care must be taken to ensure that no water can enter the chlorine stream.

### 3.2.2.3 *Displacement by a Heating System*

This method, although not recommended in North America, can be used provided the following safety provisions are applied:

- Maximum temperature of the vessel less than 50°C (40°C in Japan) (usually based on the design pressure of the vessel).
- Maximum temperature of the heating source less than 120°C (to avoid reaction between iron and chlorine).
- Direct steam, infrared heaters and electric tracing shall not be used because of the risk of overheating.

## 3.3 Off-loading Operations

### 3.3.1 Before Off-loading

Ensure the adequate state of the overall installation.

When off-loading into a storage tank, select the storage tanks to be used and ensure that there is sufficient volume available to contain the chlorine.

Ensure the adequate functioning of the gas absorption system.

#### 3.3.1.1 *The Container Itself*

Confirm that the nature and quantity of product contained in the container is correct as indicated (labeling and consignment notes).

Carry out a visual check of the adequate state of valves and flanges which are to be used in the connections. All defects should be notified immediately to the chlorine supplier.

Check on the wheel chocks and other protective devices to ensure that the container cannot be moved during its loading operation, as indicated in Section 1.1.

### 3.3.1.2 Connections

Note: All joint rings or gaskets on the flexible connections should be replaced with each connection and the flange faces should be cleaned. The connections must be made correctly in accordance with the manufacturer's recommendations. This is to avoid any failures in this area. The operator *should attach particular importance to this operation.*

The connections should be made in the following order:

- Gas phase connections
- Liquid phase connections (when used)
- The motive force for the valves, in accordance with the operating instructions laid down by the valve supplier

A pressure check of the connections should be completed prior to introducing liquid chlorine. This should be done with the pad gas. It can also be done by opening the vapor valve on the mobile container in order to confirm the gas tightness of the various connections. At this stage the fixed installation liquid valve should remain closed. A check of the container pressure should be made at this time.

### 3.3.2 Off-loading

The station should be equipped with a device to quickly shutoff the valves at the tank in the event of an emergency. Consideration should be given to having area chlorine sensors that will detect chlorine leaks and automatically close the valves at the tank.

Before starting the off-loading, ensure that all valves on the installation are in the correct position, and, in particular, verify that the connection from the liquid and gaseous chlorine piping to the absorption system has been closed. If the off-loading is carried out by pad gas pressure, adhere to the recommendations of Section 3.2.1 and ensure that the gas dryness and the differential pressure between the container being emptied and the storage system are maintained.

Whatever the destination of the chlorine being off-loaded (direct use or storage system), the container being emptied should be under continuous supervision, either visually or by television monitor. Automatic means to detect chlorine releases should also be installed.. The user must also be able to check the quantity of chlorine remaining in the container, confirm no contamination has occurred, and that pressures are not increasing due to the presence of inert gas.

It is recommended that the transfer operation should be carried on until all practical amounts of liquid have been removed. This is limited by the dip pipe configuration in the container. Residual pressure should be left in the container (1.2 bars) to avoid a sub-atmospheric pressure on the return journey.

### 3.3.3 Empty Container

The container should be isolated from the point of use or storage system. Where it has been emptied by being put under pressure of inert gas, a venting down

operation should be carried out in order to avoid any possibility of the maximum operating pressure of the container being exceeded during its return journey.

### 3.3.4 Purging of Connections

The flexible connections between the isolation valves should be purged between each off-loading operation. For installations receiving only small quantities of chlorine, the piping between the storage system, or point of use, and the flexible connections should also be emptied.

This purging operation should be carried out until the disappearance of any frosting. After venting down, the flexible connections should be maintained under a dry air or nitrogen purge.

### 3.3.5 Disconnection

For these operations it is recommended that the operating personnel should wear breathing protection equipment. These operations should be carried out in the following order:

- Disconnect the motive force for the container automated valves.
- Manually close the pneumatic valves on the chlorine container
- Disconnect the chlorine connections
- Check the gas tightness of the container valves
- Reinstall the blind flanges with a new ring joint or gasket on the valves of the transport container
- Isolate of the flexible connections and of the fixed installation flanges with a blind flange in order to avoid their contamination due to atmospheric humidity

## 4 Drums and Cylinders

A written check list should be used, including, if appropriate, the approval of a supervisor before starting the filling of the equipment.

### 4.1 Preliminary Checks

- Check for hydraulic test date
- Check for dents and scratches
- Check whether or not maintenance inspection is required
- Check whether or not cylinder valve replacement is required.
- If the container passes inspection then place it in the loading area
- Some facilities conduct boroscope (internal inspection) of the cylinder internals prior to filling after return from the customer.

All precautions should be taken to avoid the movement of the container during the course of loading.

## 4.2 Connection of the Container to the Loading Station

Flow for Filling a Liquid Chlorine Ton Cylinder is shown in Appendix 7. Flexible steel pipes are generally used. See Section 1.6.

## 4.3 Degassing and Purging the Container

Note: If there is no remaining pressure or the container is depressurized below atmospheric pressure, clean and dry the container and, if possible, check the inside surface of the container. (This process is strongly recommended because there may be moisture inside the container).

The below procedure is one method to remove chlorine remaining in a cylinder.

- Repeatedly open and close the vapor valve to facility handling system. The process of releasing pressure is complete when the scrubbing system pressure gauge reading does not change
- Check that there is no frost on the bottom of the cylinder.

## 4.4 Gland Nuts and Spindle

- Remove the gland nuts and spindle
- Place a separation plate over the opening of the valve (to prevent moisture from entering).
- Clean and dry the spindle and packing
- Lathe the spindle surface that is in contact with the valve seat prior to reuse
- Reinstall all removed pieces

## 4.5 Cleaning Valve, Gland Nut and Fitting

Valves should be disassembled and cleaned (typically with steam) and dried using dry air (-40<sup>0</sup> C. dew point). The valve should then be reassembled and tested with dry air using a soap solution. Valves should not be reused if they have pitting or other defects that might make them less than fully reliable.

Gland nuts should be checked for any cracks, roundness of the corners, and for uniform thickness of the Teflon packing. Gland nuts should be rejected if they have defects that might make them less than fully reliable.

## 4.6 Keeping Records of Maintenance Operations

While not the subject of this guidance document, facilities need to perform routine maintenance tasks as required by regulatory authorities and/or their company requirements. Documentation of such tasks is critical in order to verify that they have been completed.

## 4.7 Leak Testing

Before filling, all of the valves and accessories must be tested in a fashion which will guarantee complete leak tightness in the conditions of service. The following test methods can be used:

- Test pressure of air at more than 4 bar(g) and less than the maximum operating pressure with detection of leaks by use of soap and water;
- A final test with chlorine or a mixture of chlorine and dry gas with the joints being checked by the use of an ammonia bottle. Liquid from the ammonia bottle must not be directed directly on the equipment ! The reaction between liquid ammonia and chlorine is quite violent and must be avoided.

## 4.8 Precaution against Overfilling Risk

Before beginning any loading, the amount of chlorine to be filled should be specified to prevent any risk of overfilling.

## 4.9 Disconnecting Process

- Shut all the valves
- Purge all the lines to the absorption unit
- Disconnect the container
- Leak test the valves on the container with ammonia bottle
- Plug all of the outlet connections immediately to minimize exposure to moist air
- Put the cap nut on the cylinder valves

## 4.10 Recording the Appropriate Items:

The legal requirements for information vary with the country. The following is a typical list :

- Filling date
- Name of person completing the form
- Marked weight
- Net weight
- Weight after filling
- Amount filled
- Date of the previous pressure test
- Date of the next pressure test

All this information is attached to the container

## 4.11 Confirmation of Quantity Loaded

Consideration should be given to confirming the weight of the filled container on a different weighing machine than the one used to monitor the filling (equipped with visible and audible alarm, and automatic closure of the liquid chlorine feeding valve). Some facilities do this by checking 10% of the cylinders and using this information to check the accuracy of the loading item.

Other techniques are also used by JSIA (temperature and/or pressure alarm).

#### **4.12 Place the Container in the Storage Area**

Some facilities quarantine the filled cylinders for 24 hrs to allow the loaded material to achieve room temperature and higher container pressure. They then recheck for leaks, container test dates and correct quantities (weight)

#### **4.13 Loading of the Container on to the Transport Equipment**

Before loading the container on the transport equipment, allow for a final check: external appearance and possible leak, second weight control (if not yet done), correct marking, complete documentation ...

The driver of the transport truck should be trained and should have all of the necessary instructions and protective equipment to respond to possible incidents with a chlorine leak.

## **5 APPENDICES**

Appendix 1: Flow for filling a container with chlorine pump

Appendix 2: Flow for filling a container with chlorine gas pressure

Appendix 3: Off loading to user in the gaseous phase

Appendix 4: Off loading to user in the liquid phase with dry gas pressure

Appendix 5: Off loading to stock tank in the liquid phase with dry gas pressure

Appendix 6: Off loading to stock tank in the liquid phase with compressor

Appendix 7: Flow for filling a liquid chlorine ton cylinder

## APPENDIX 1: FLOW FOR FILLING A CONTAINER WITH CHLORINE PUMP

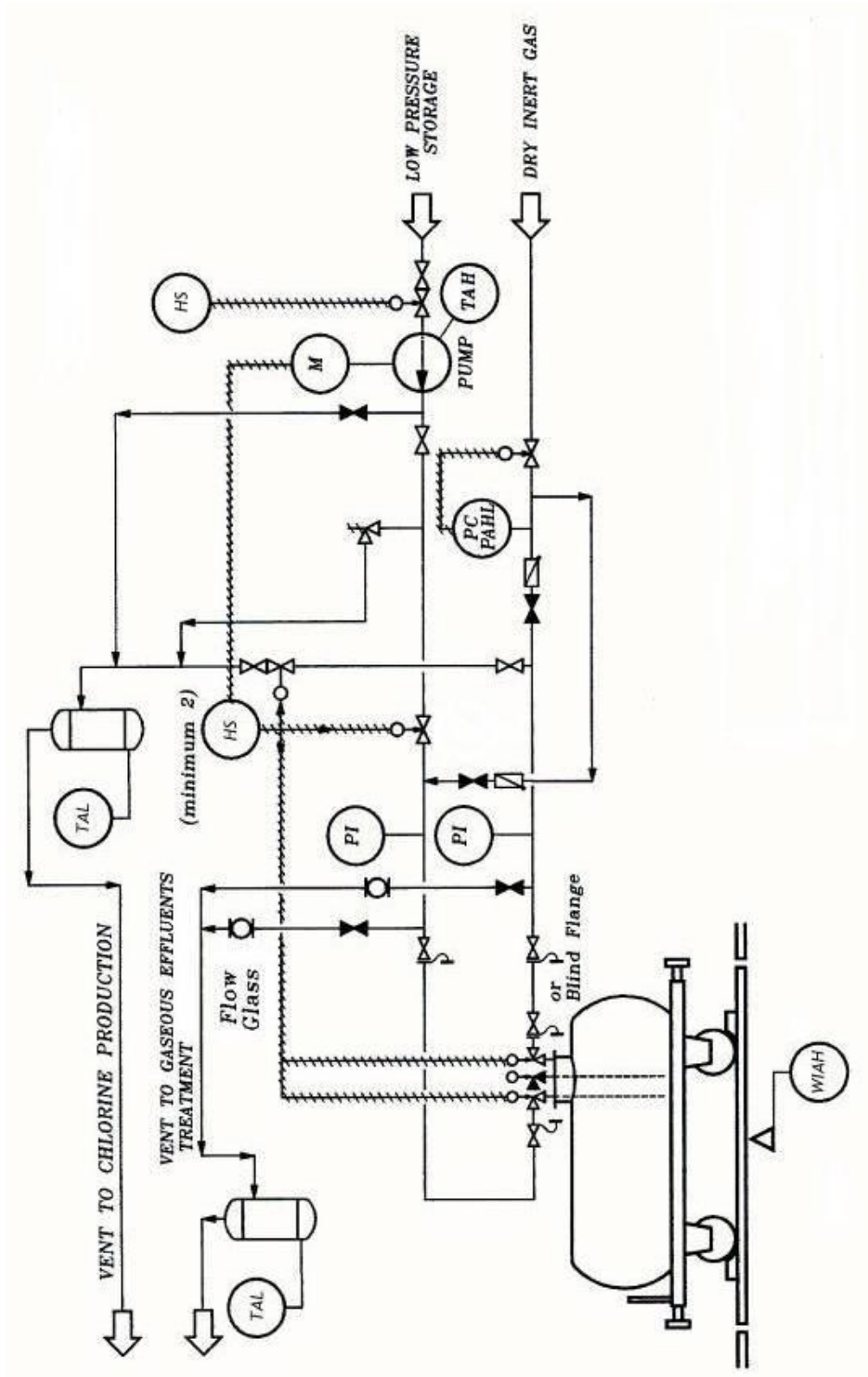

## APPENDIX 2: FLOW FOR FILLING A CONTAINER BY CHLORINE GAS PRESSURE

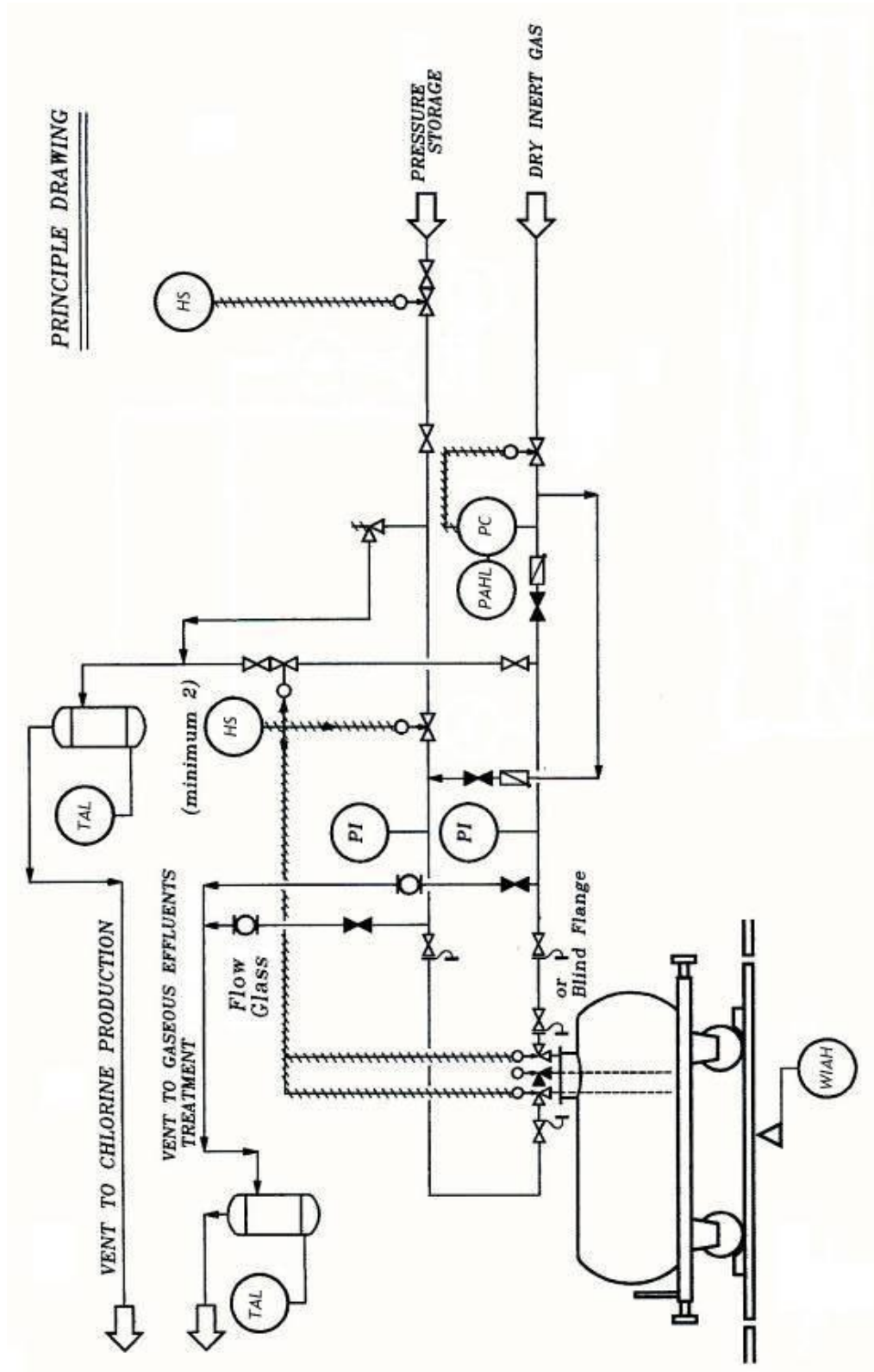

## APPENDIX 3: OFF-LOADING TO USER IN THE GASEOUS PHASE

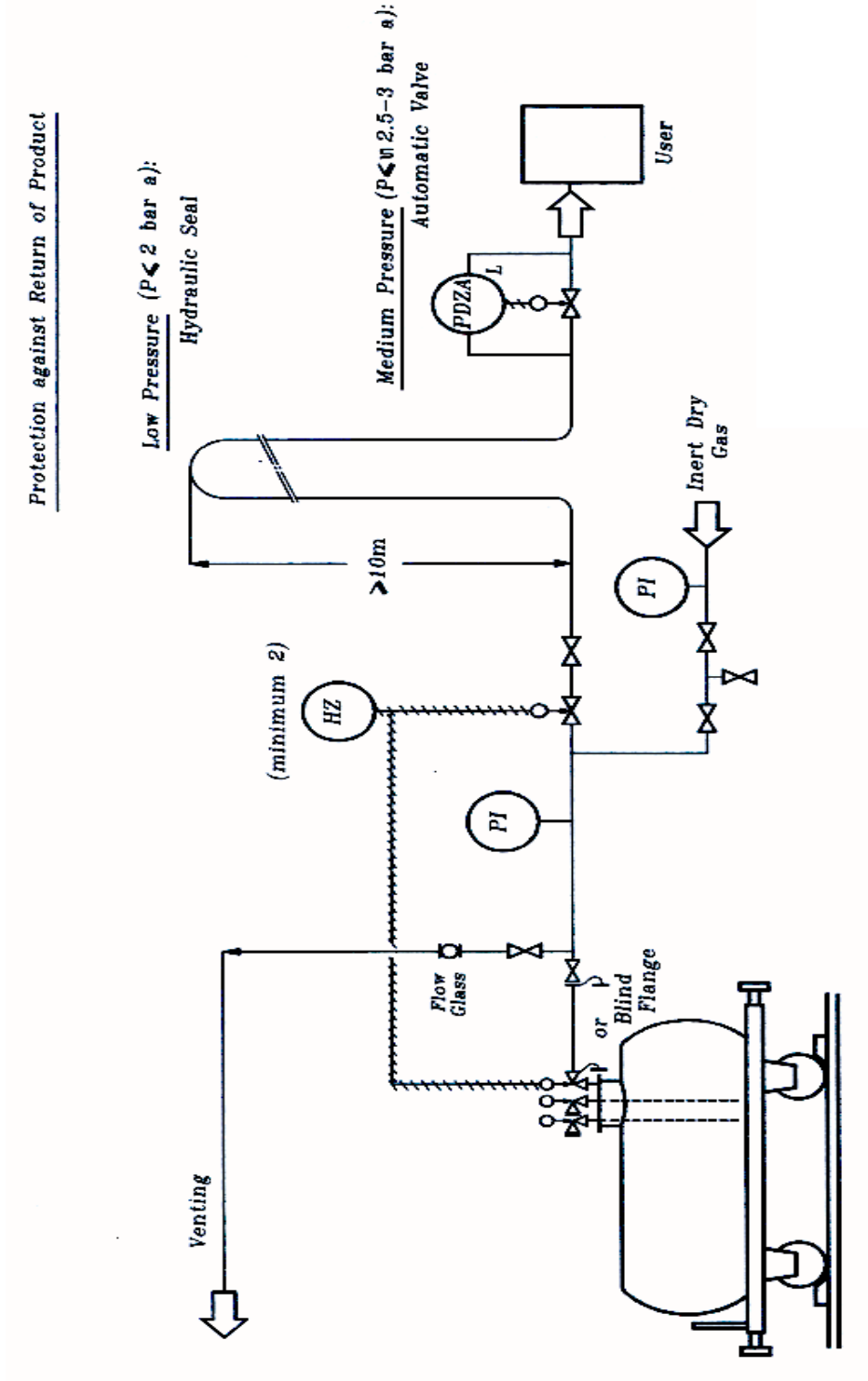

## APPENDIX 4: OFF-LOADING TO USER IN THE LIQUID PHASE WITH DRY GAS PRESSURE

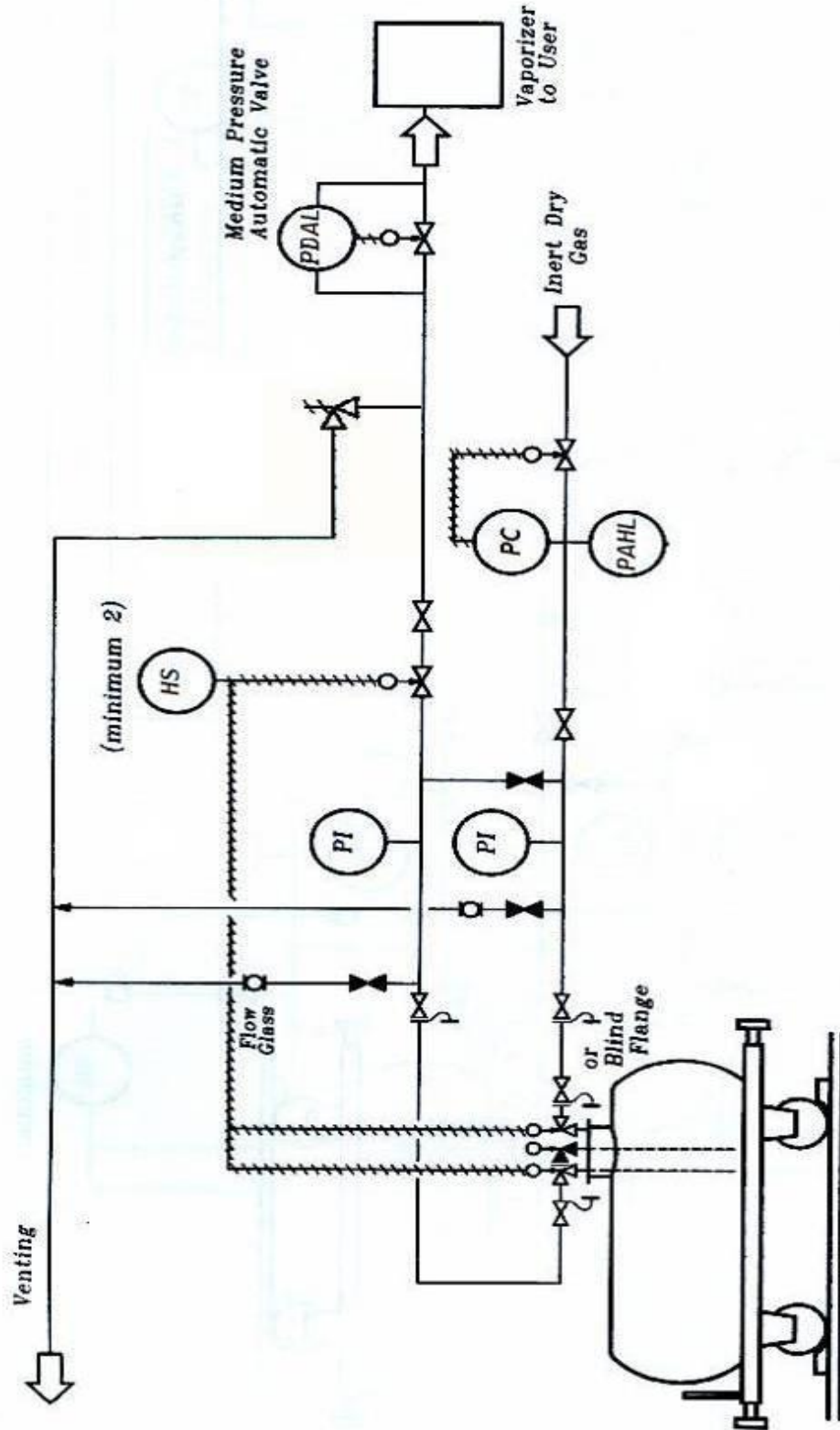

## APPENDIX 5: OFF-LOADING TO STOCK TANK IN THE LIQUID PHASE WITH DRY GAS PRESSURE

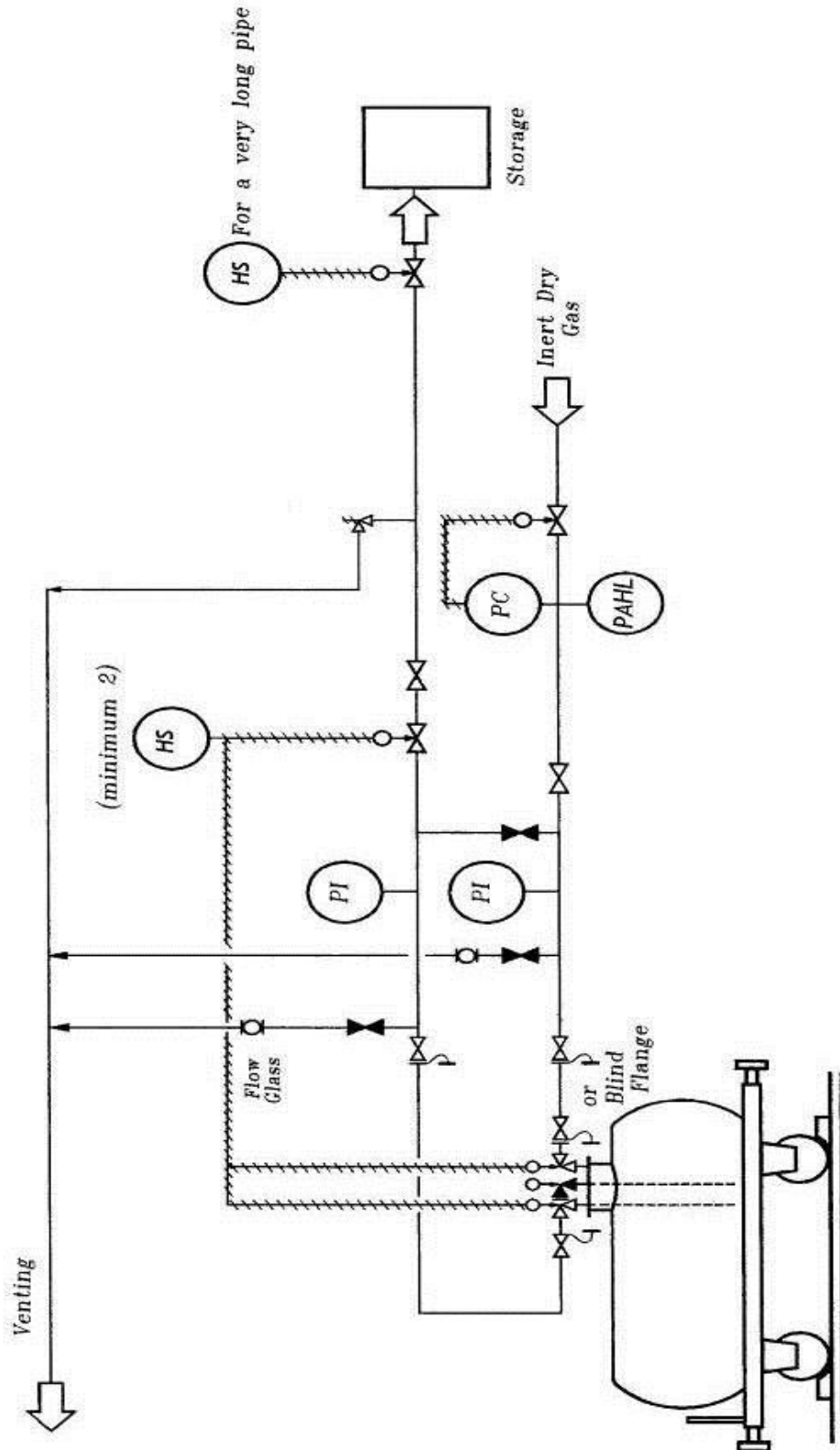

## APPENDIX 6: OFF-LOADING TO STOCK TANK IN THE LIQUID PHASE WITH COMPRESSOR

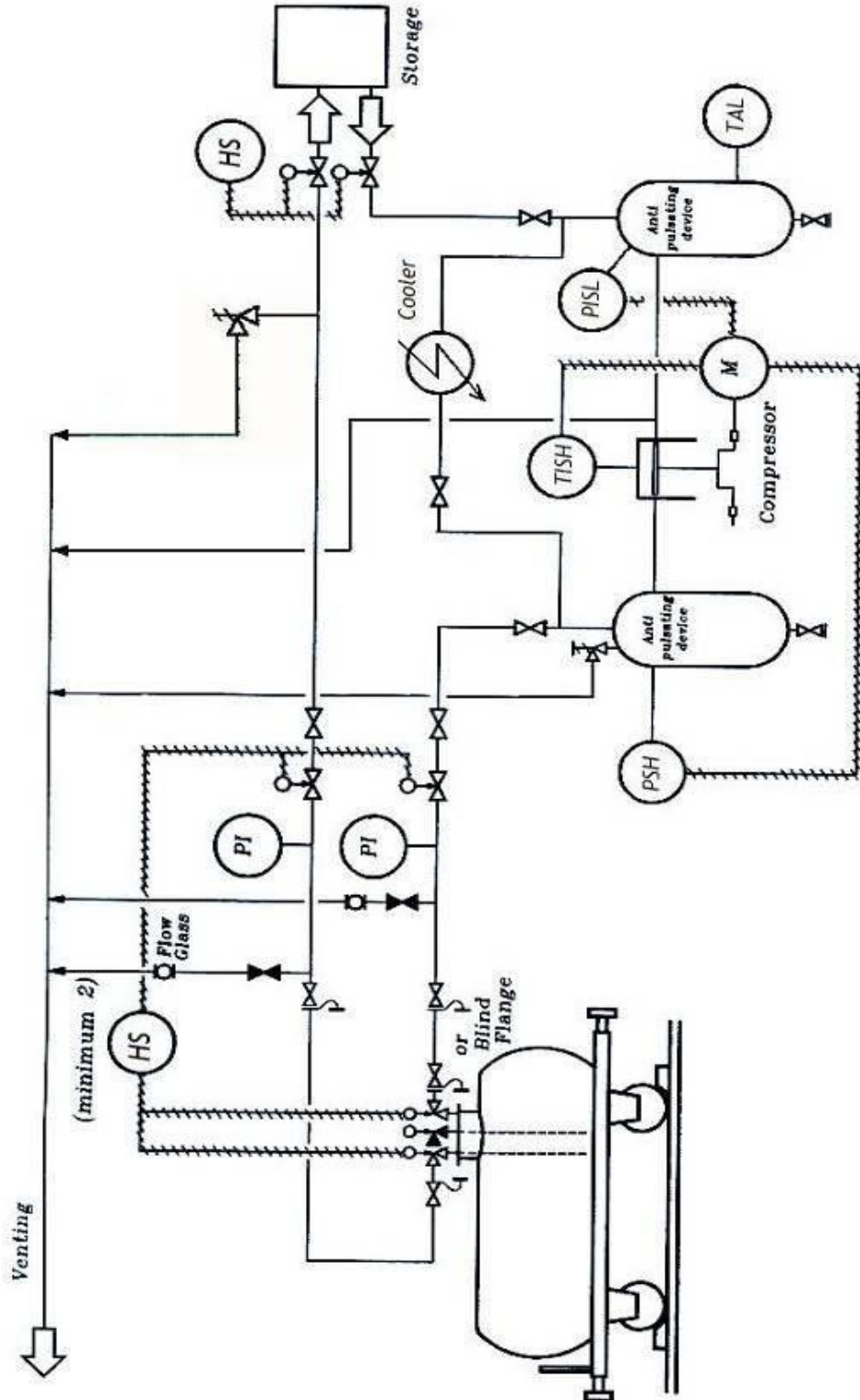

## APPENDIX 7: FLOW FOR FILLING A LIQUID CHLORINE TON CYLINDER

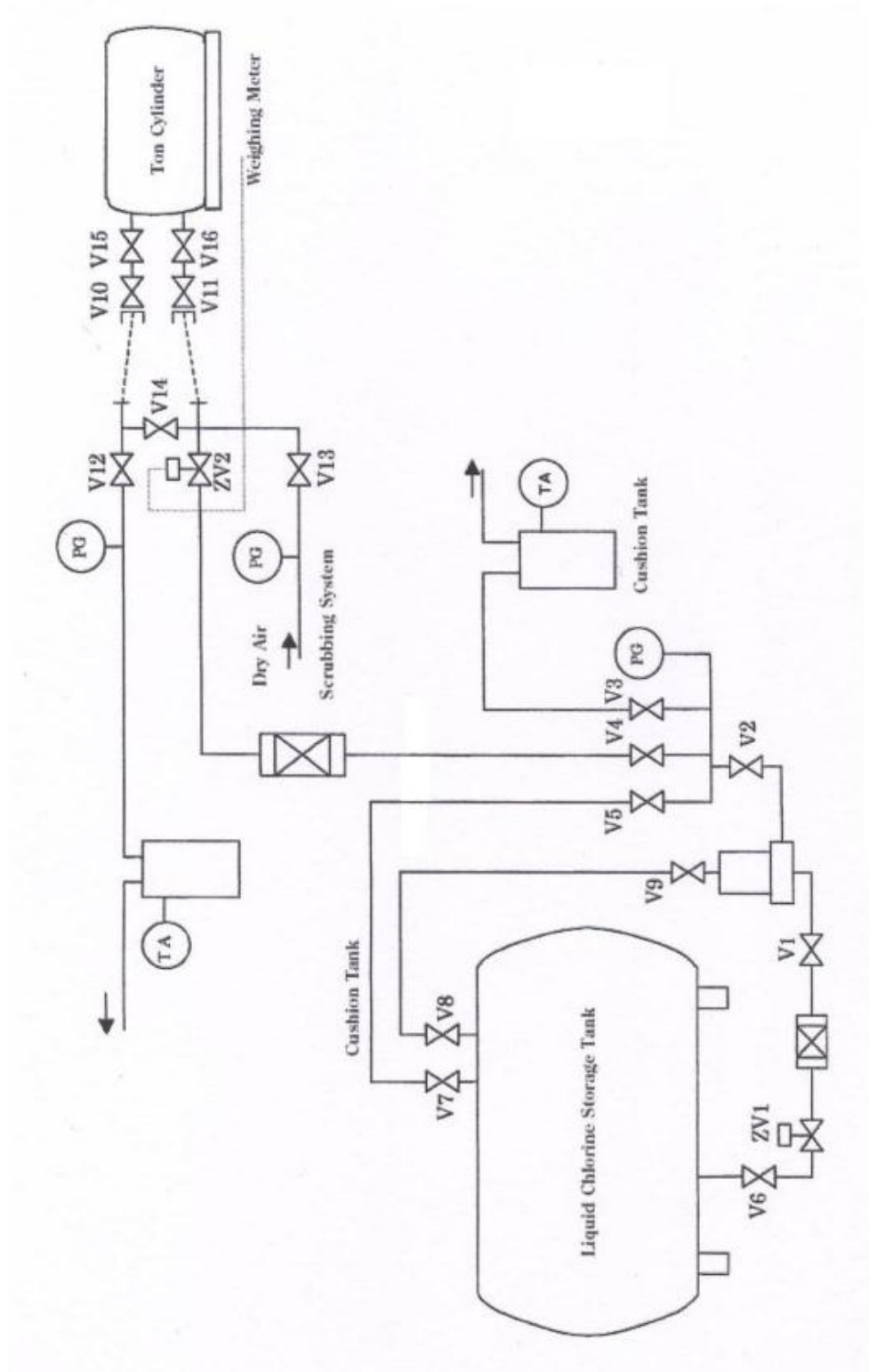

## 6 CHECKLISTS

Sample checklists have been prepared to assist the user of this document in verifying compliance with key aspects of the topic area. These sample checklists were prepared by a regional association member (AMAI) of WCC. Not all of the items listed may be applicable to the user's region. The user is encouraged to review the checklists provided and modify them as deemed appropriate for use at the user's site. The check lists should not be considered all-inclusive of the recommendations in this publication. The checklists have been designed to emphasize major topics for someone who has already read and understood the publication. Taking recommendations from such checklists without understanding related topics can lead to inappropriate conclusions.

The sample checklists include the following topics:

- Storage
- Pre-loading into a vehicle
- Loading into a Vehicle
- Transportation
- Off-loading from a vehicle
- Processing
- Disconnecting after off-loading

## Sample Checklist for the Storage Area

Place a check mark (✓) in the appropriate box below:

Yes	No	N/A	
<input type="checkbox"/>	<input type="checkbox"/>	<input type="checkbox"/>	Is the storage location SHADED and DRY?
<input type="checkbox"/>	<input type="checkbox"/>	<input type="checkbox"/>	Is there ADEQUATE ventilation?
<input type="checkbox"/>	<input type="checkbox"/>	<input type="checkbox"/>	Is there no source of heat NEARBY?
<input type="checkbox"/>	<input type="checkbox"/>	<input type="checkbox"/>	Are there ANY OTHER chemicals stored in the area?
<input type="checkbox"/>	<input type="checkbox"/>	<input type="checkbox"/>	Are there any corrosive fumes from NEARBY area?
<input type="checkbox"/>	<input type="checkbox"/>	<input type="checkbox"/>	Is the area NEAT and CLEAN?
<input type="checkbox"/>	<input type="checkbox"/>	<input type="checkbox"/>	Is the gangway FREE?
<input type="checkbox"/>	<input type="checkbox"/>	<input type="checkbox"/>	Is the container SECURED with wooden wedges on BOTH SIDES?
<input type="checkbox"/>	<input type="checkbox"/>	<input type="checkbox"/>	Are filled tonners arranged in a SINGLE ROW?
<input type="checkbox"/>	<input type="checkbox"/>	<input type="checkbox"/>	Are there SEPARATE ROWS for empty tonners?
<input type="checkbox"/>	<input type="checkbox"/>	<input type="checkbox"/>	Are the valves in a VERTICAL plane?
<input type="checkbox"/>	<input type="checkbox"/>	<input type="checkbox"/>	Are the tags CORRECT?
<input type="checkbox"/>	<input type="checkbox"/>	<input type="checkbox"/>	Is there SPECIFIED DISTANCE from the connected tonners in the process?
<input type="checkbox"/>	<input type="checkbox"/>	<input type="checkbox"/>	Is there no hot job WITHOUT a work permit?
<input type="checkbox"/>	<input type="checkbox"/>	<input type="checkbox"/>	Are unauthorized persons PROHIBITED from entering?
<input type="checkbox"/>	<input type="checkbox"/>	<input type="checkbox"/>	Is an Emergency Kit ready at an IDENTIFIED PLACE?
<input type="checkbox"/>	<input type="checkbox"/>	<input type="checkbox"/>	Is self-contained breathing apparatus located at an IDENTIFIED PLACE?
<input type="checkbox"/>	<input type="checkbox"/>	<input type="checkbox"/>	Do tonners not lie for MORE THAN ONE MONTH unused?
<input type="checkbox"/>	<input type="checkbox"/>	<input type="checkbox"/>	Is there a PERIODIC CHECK for leakage with an ammonia torch?

## Sample Checklist for Pre-loading into a Vehicle

Place a check mark (✓) in the appropriate box below:

Yes	No	N/A	
<input type="checkbox"/>	<input type="checkbox"/>	<input type="checkbox"/>	Has leakage been CHECKED for with an ammonia torch?
<input type="checkbox"/>	<input type="checkbox"/>	<input type="checkbox"/>	Is the spindle of the valve in the CORRECT SHAPE?
<input type="checkbox"/>	<input type="checkbox"/>	<input type="checkbox"/>	Are the valve caps FITTED?
<input type="checkbox"/>	<input type="checkbox"/>	<input type="checkbox"/>	Is the valve protection hood (bonnet) FITTED?
<input type="checkbox"/>	<input type="checkbox"/>	<input type="checkbox"/>	Has the PHYSICAL CONDITION of the tonner been checked?
<input type="checkbox"/>	<input type="checkbox"/>	<input type="checkbox"/>	Has the hydraulic TEST DATE been checked?
<input type="checkbox"/>	<input type="checkbox"/>	<input type="checkbox"/>	Are BOTH SIDE COVERS of vehicles operable?
<input type="checkbox"/>	<input type="checkbox"/>	<input type="checkbox"/>	Is there a vehicle without a top hood?
<input type="checkbox"/>	<input type="checkbox"/>	<input type="checkbox"/>	Is the breadth of the vehicle slightly MORE THAN the length of the tonner?
<input type="checkbox"/>	<input type="checkbox"/>	<input type="checkbox"/>	Is the vehicle NOT LOADED with paints, oils, grease, turpentine and food?
<input type="checkbox"/>	<input type="checkbox"/>	<input type="checkbox"/>	Is an Emergency Kit KEPT in the vehicle?
<input type="checkbox"/>	<input type="checkbox"/>	<input type="checkbox"/>	Is a CO <sub>2</sub> type fire extinguisher KEPT in the vehicle?
<input type="checkbox"/>	<input type="checkbox"/>	<input type="checkbox"/>	Are breathing apparatus, gas mask KEPT in the vehicle?
<input type="checkbox"/>	<input type="checkbox"/>	<input type="checkbox"/>	Is there a CORRECT emergency information panel?
<input type="checkbox"/>	<input type="checkbox"/>	<input type="checkbox"/>	Are required and optional safety materials kept WITH THE DRIVER?
<input type="checkbox"/>	<input type="checkbox"/>	<input type="checkbox"/>	Is the vehicle COVERED with a tarpaulin?

## Sample Checklist for Loading into a Vehicle

Place a check mark (✓) in the appropriate box below:

- | Yes                      | No                       | N/A                      |  |
|--------------------------|--------------------------|--------------------------|--|
| <input type="checkbox"/> | <input type="checkbox"/> | <input type="checkbox"/> | Has it been verified that the vehicle is STOPPED and brakes APPLIED? |
| <input type="checkbox"/> | <input type="checkbox"/> | <input type="checkbox"/> | Are tonners in a SINGLE ROW?   |
| <input type="checkbox"/> | <input type="checkbox"/> | <input type="checkbox"/> | Are tonners SECURED WITH wooden wedges, rope / sling wire?           |
| <input type="checkbox"/> | <input type="checkbox"/> | <input type="checkbox"/> | Are there NOT MORE THAN SIX tonners in a vehicle (standard size)?    |
| <input type="checkbox"/> | <input type="checkbox"/> | <input type="checkbox"/> | Are tonners not PROJECTED outside the vehicle?                       |
| <input type="checkbox"/> | <input type="checkbox"/> | <input type="checkbox"/> | Is the tonner valve in a VERTICAL plane?                             |

## Sample Checklist for Transportation

Place a check mark (✓) in the appropriate box below:

- | Yes                      | No                       | N/A                      |   |
|--------------------------|--------------------------|--------------------------|---|
| <input type="checkbox"/> | <input type="checkbox"/> | <input type="checkbox"/> | Have the brakes been CHECKED?                                   |
| <input type="checkbox"/> | <input type="checkbox"/> | <input type="checkbox"/> | Does the driver drive at the speed LIMIT?                       |
| <input type="checkbox"/> | <input type="checkbox"/> | <input type="checkbox"/> | Is the driver not UNDER THE INFLUENCE of alcohol?               |
| <input type="checkbox"/> | <input type="checkbox"/> | <input type="checkbox"/> | Has the vehicle been checked for leakage with an ammonia torch? |

## Sample Checklist for Unloading

Place a check mark (✓) in the appropriate box below:

Yes	No	N/A	
<input type="checkbox"/>	<input type="checkbox"/>	<input type="checkbox"/>	Have vehicle brakes been APPLIED and is the engine STOPPED?
<input type="checkbox"/>	<input type="checkbox"/>	<input type="checkbox"/>	Is the vehicle under the SUPERVISION of a trained and experienced person?
<input type="checkbox"/>	<input type="checkbox"/>	<input type="checkbox"/>	Is a crane/hoist/chain pulley block being USED?
<input type="checkbox"/>	<input type="checkbox"/>	<input type="checkbox"/>	Are tonners NOT BEING DROPPED DIRECTLY to the ground?

## Sample Checklist for Processing

Place a check mark (✓) in the appropriate box below:

Yes	No	N/A	
<input type="checkbox"/>	<input type="checkbox"/>	<input type="checkbox"/>	Container ON weighting platform?
<input type="checkbox"/>	<input type="checkbox"/>	<input type="checkbox"/>	Are tonners SECURED WITH wooden wedges on BOTH SIDES?
<input type="checkbox"/>	<input type="checkbox"/>	<input type="checkbox"/>	Are valves in VERTICAL planes?
<input type="checkbox"/>	<input type="checkbox"/>	<input type="checkbox"/>	Are STANDARD tools and accessories being used?
<input type="checkbox"/>	<input type="checkbox"/>	<input type="checkbox"/>	Are pressure gauges in WORKING CONDITION?
<input type="checkbox"/>	<input type="checkbox"/>	<input type="checkbox"/>	Are the inverted "U" loop / non-return valve IN SERVICE?
<input type="checkbox"/>	<input type="checkbox"/>	<input type="checkbox"/>	Is the pressure regulating valve IN SERVICE?
<input type="checkbox"/>	<input type="checkbox"/>	<input type="checkbox"/>	Is a neutralization system AVAILABLE?
<input type="checkbox"/>	<input type="checkbox"/>	<input type="checkbox"/>	Is the Emergency Kit IN ORDER?
<input type="checkbox"/>	<input type="checkbox"/>	<input type="checkbox"/>	Is self-contained breathing apparatus AVAILABLE?
<input type="checkbox"/>	<input type="checkbox"/>	<input type="checkbox"/>	Has an ammonia torch been used to CHECK for leakage?
<input type="checkbox"/>	<input type="checkbox"/>	<input type="checkbox"/>	Is connection made with YOKE CLAMPS and COPPER TUBING?
<input type="checkbox"/>	<input type="checkbox"/>	<input type="checkbox"/>	Is the valve key kept FIXED to all the valves in service?
<input type="checkbox"/>	<input type="checkbox"/>	<input type="checkbox"/>	Are tonners NOT BEING USED as process vessels?
<input type="checkbox"/>	<input type="checkbox"/>	<input type="checkbox"/>	Are tonners used in ORDER OF RECEIPT?
<input type="checkbox"/>	<input type="checkbox"/>	<input type="checkbox"/>	No tonner HEATING for withdrawing more chlorine?
<input type="checkbox"/>	<input type="checkbox"/>	<input type="checkbox"/>	Is there slight POSITIVE chlorine pressure in the empty tonner?
<input type="checkbox"/>	<input type="checkbox"/>	<input type="checkbox"/>	Has it been verified that no lubricant or oil is NEAR the chlorine tonners?
<input type="checkbox"/>	<input type="checkbox"/>	<input type="checkbox"/>	Are TEFLON gaskets being used?

## Sample Checklist for Disconnecting after Off-loading

Place a check mark (✓) in the appropriate box below:

Yes	No	N/A	
<input type="checkbox"/>	<input type="checkbox"/>	<input type="checkbox"/>	Are breathing apparatus / canister gas mask and safety appliances being USED while DISCONNECTING?
<input type="checkbox"/>	<input type="checkbox"/>	<input type="checkbox"/>	Was this sequence for disconnecting the tonner followed: CLOSE tonner valve; CLOSE process valve; NEUTRALIZE trapped chlorine; DISCONNECT fittings.
<input type="checkbox"/>	<input type="checkbox"/>	<input type="checkbox"/>	Valve cap FITTING secure?
<input type="checkbox"/>	<input type="checkbox"/>	<input type="checkbox"/>	Has the valve protective device (bonnet) been FITTED?
<input type="checkbox"/>	<input type="checkbox"/>	<input type="checkbox"/>	Has the tonner TAG been emptied?
<input type="checkbox"/>	<input type="checkbox"/>	<input type="checkbox"/>	STACKING in empty tonner row?
<input type="checkbox"/>	<input type="checkbox"/>	<input type="checkbox"/>	Are the valves in a VERTICAL plane?
<input type="checkbox"/>	<input type="checkbox"/>	<input type="checkbox"/>	Has this final check been made before dispatch: Verify PHYSICAL CONDITIONS of tonners and valves; Verify FITNESS of valve caps and protective device (bonnet)
<input type="checkbox"/>	<input type="checkbox"/>	<input type="checkbox"/>	Has any ABNORMAL observation been conveyed to the supplier?

## **7 REFERENCE DOCUMENTS**

### **7.1 Euro Chlor**

GEST 75/43, Flexible Steel Pipes and Flexible High Nickel Alloys Hoses for the Transfer of Dry Gaseous or Liquid Chlorine

GEST 78/73, Design Principles and Operational Procedures for Loading/Off-Loading Liquid Chlorine Road and Rail Tankers and ISO-Containers

GEST 88/138, Small Chlorine Containers Construction and Handling

### **7.2 Japanese Soda Industry Association**

Important Points in Preventing Incidents with Chlorine (During Filling, Transporting and Unloading) July, 2005

### **7.3 Chlorine Institute**

Pamphlet 66, Recommended Practices for Handling Chlorine Tank Cars

Pamphlet 49, Recommended Practices for Handling Chlorine Bulk Highway Transports

Pamphlet 57, Emergency Shut-Off Systems for Bulk Transfer of Chlorine

### **7.4 Alkali Manufacturers' Association of India**

Safe Handling of Chlorine – A Guide for Consumers

### **7.5 RusChlor**

Safe Rules for the Production, Transportation, and Use of Chlorine (available only in Russian)